

Renogy

500A Combiner Box

(Advanced Version)

REC500CB-98CM

VERSION A0
January 18, 2024

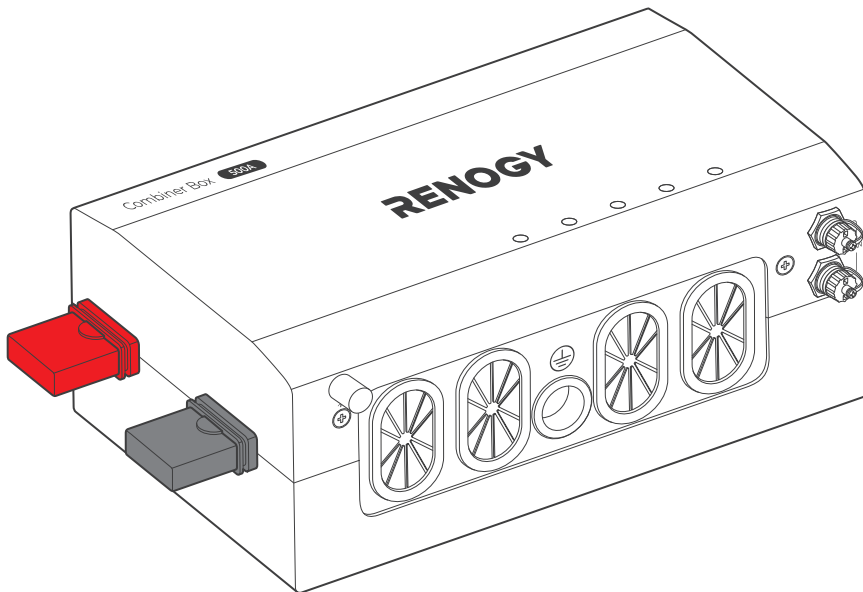

USER MANUAL

Before Getting Started

The user manual provides important operation and maintenance instructions for Renogy 500A Combiner Box (Advanced Version) (hereinafter referred to as combiner box).

Read the user manual carefully before operation and save it for future reference. Failure to observe the instructions or precautions in the user manual can result in electrical shock, serious injury, or death, or can damage the combiner box, potentially rendering it inoperable.

- Renogy ensures the accuracy, sufficiency, and the applicability of information in the user manual at the time of printing due to continual product improvements that may occur.
- Renogy assumes no responsibility or liability for personal and property losses, whether directly and indirectly, caused by the user's failure to install and use the product in compliance with the user manual.
- Renogy is not responsible or liable for any failure, damage, or injury resulting from repair attempts by unqualified personnel, improper installation, or inappropriate operation.
- The illustrations in the user manual are for demonstration purposes only. Details may appear slightly different depending on product revision and market region.
- Renogy reserves the right to change the information in the user manual without notice. For the latest user manual, visit [renogy.com](https://www.renogy.com).

Disclaimer

Renogy 500A Combiner Box (Advanced Version) User Manual © 2024 Renogy. All rights reserved.

RENOGY and **RENOGY** are registered trademarks of Renogy.

- All information in the user manual is subject to copyright and other intellectual property rights of Renogy and its licensors. The user manual may not be modified, reproduced, or copied, in whole or in part, without the prior written permissions of Renogy and its licensors.
- The registered trademarks in the user manual are the property of Renogy. The unauthorized use of the trademarks is strictly prohibited.

Online Manual

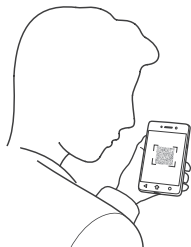

User Manual



Table of Contents

Symbols Used	1
Introduction	1
Key Features	1
SKU	2
What's In the Box?	2
Required Tools & Accessories	2
Get to Know Renogy 500A Combiner Box	3
Wiring Diagram	4
With MRBF Fuses.....	4
With ANL Fuses.....	5
Dimensions	6
How to Size Cables?	6
How to Install the 3/8 in Lugs (M10 Ring Terminals)?	7
How to Connect Power Supply Devices to the Busbars Safely?	8
Step 1. Plan a Mounting Site	9
Step 2. Wear Insulating Gloves	9
Step 3. Remove the Cover	9
Step 4. Mount the Combiner Box	10
Step 5. Ground the Combiner Box	10
Step 6. Installing the Voltage Sensor (Optional)	10
Step 7. Connect Power Supply Devices to the Combiner Box	12
With MRBF Fuse.....	12
With ANL Fuse.....	14
Step 8. Wire Inspection and Install the Cover	15
CAN Communication Wiring (Optional)	15
Interconnecting Combiner Boxes	21
LED Indicators & Troubleshooting	22
Monitoring	23
Short-Range Monitoring.....	24
Wireless Long-Range Monitoring.....	25
Wired Long-Range Monitoring (Backbone Network)	26
Wired Long-Range Monitoring (Daisy Chain Network).....	27

Specifications28

Maintenance.....28

 Inspection.....28

 Cleaning28

Important Safety Instructions29



 General29

 Combiner Box Safety.....29

Renogy Support30

Symbols Used

The following symbols are used throughout the user manual to highlight important information.

-  **WARNING:** Indicates a potentially dangerous condition which could result in injury or death.
-  **CAUTION:** Indicates a critical procedure for safe and proper installation and operation.
-  **NOTE:** Indicates an important step or tip for optimal performance.

Introduction

Renogy 500A Combiner Box (Advanced Version) is a reliable, space-efficient cable hub for electrical connection and distribution, simplifying wiring in your solar power system.

It is equipped with two busbars (a negative and a positive) that offer four connections for batteries (12V, 24V, 36V, and 48V), loads, or battery chargers, along with a ground connection. It also allows for easy expansion of the system by connecting the box to other combiner boxes through the built-in extended terminals.

The combiner box includes LEDs that display the operating status (on/off) of the connected device, simplifying troubleshooting while ensuring safety.

In addition, you can also check the connected device status in the DC Home app or Renogy ONE via Bluetooth.

Key Features

- **Safety and Stability**
The combiner box is equipped with two busbars and supports the installation of fuses, especially Marine Rated Battery (MRBF) fuses, to ensure electrical safety. This also simplifies installation and maintenance with quicker installation and less effort.
- **Compact and Lightweight Design**
The combiner box is compact and lightweight, making it easy to install in any location, while also providing sufficient internal space to accommodate thick wires and larger terminals.
- **Sturdy Outer Casing**
The combiner box protects the system connections with a sturdy outer casing, which remains intact even when subjected to wire bending or twisting.
- **Long-Time Stable Running**
The high-quality tin-plated copper busbars inside ensure the system operates reliably for extended periods.
- **Simplified Troubleshooting**
The equipped LEDs accurately indicate the electrical connection status of the specific device. You can also monitor the device status in the DC Home app or Renogy ONE Core remotely and locally via Bluetooth.

SKU

Renogy 500A Combiner Box (Advanced Version)

REC500CB-98CM

What's In the Box?

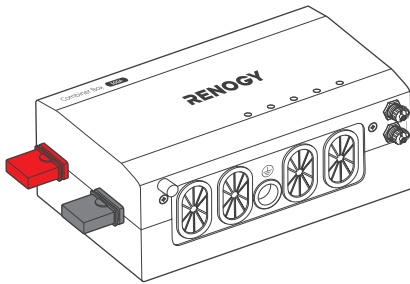

Renogy 500A Combiner Box × 1



User Manual × 1

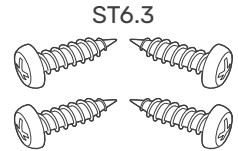

Self-tapping Screws × 4

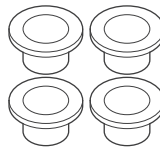

Insulating Sleeves × 4

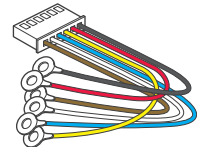

Voltage Sensor × 1

i Make sure the combiner box is free of any signs of damage.

Required Tools & Accessories

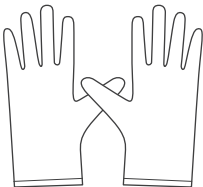

Insulating Gloves



Phillips
Screwdriver (#2)

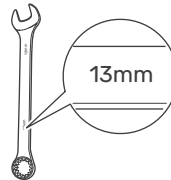

Wrench (17/32 in)

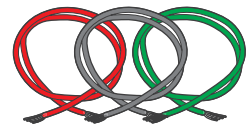

Bare Wires



Wire Stripper

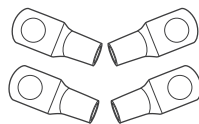

3/8 in Lugs
(M10 Ring Terminals)

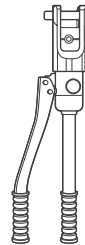

Manual
Hydraulic Pliers

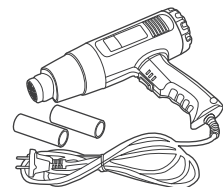

Heat Gun and
Heat Shrink Tubing

i Prior to installing and configuring the combiner box, prepare the recommended tools, components, and accessories.

i For how to size bare wires, refer to [“How to Size Cables?”](#) in this manual.

Get to Know Renogy 500A Combiner Box

Exterior

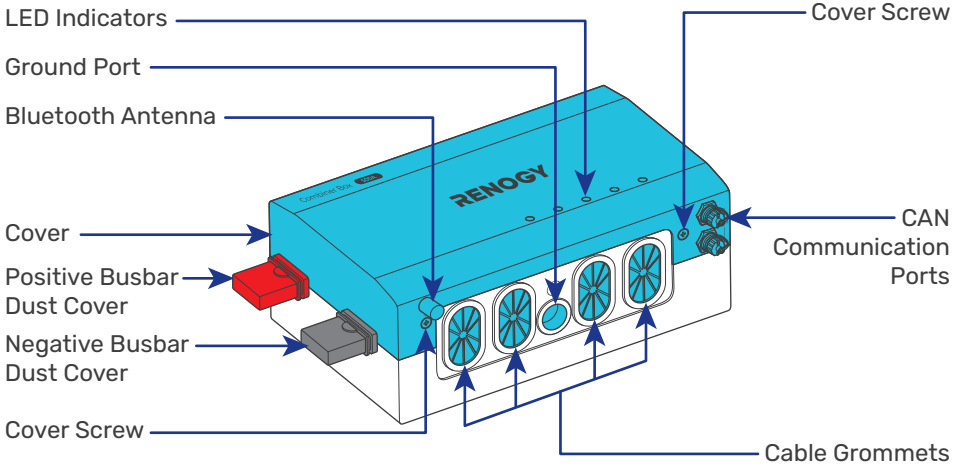

Interior (with the cover removed)

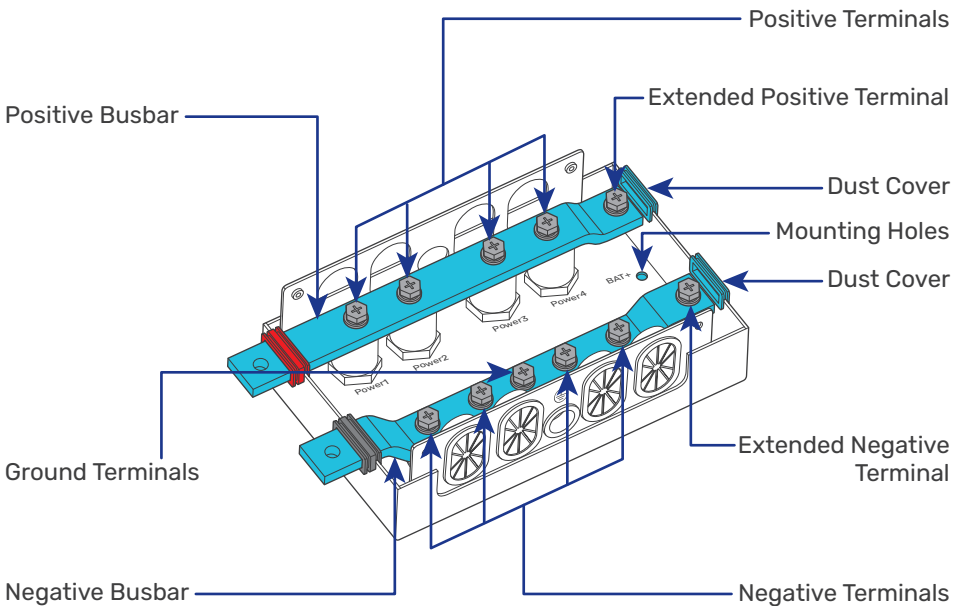

i Each busbar terminal is equipped with a terminal bolt, a spring washer, and a flat washer.

Wiring Diagram

- ⚠ The combiner box is designed to withstand a continuous current not surpassing 500A, while maintaining an operational voltage range between 9V and 60V DC.
- i The wiring diagram only shows the key components in a typical DC-coupled residential energy storage system for the illustrative purpose. The wiring might be different depending on the system configuration. Additional safety devices, including disconnect switches, emergency stops, and rapid shutdown devices, might be required. Wire the system in accordance with the regulations at the installation site.

With MRBF Fuses

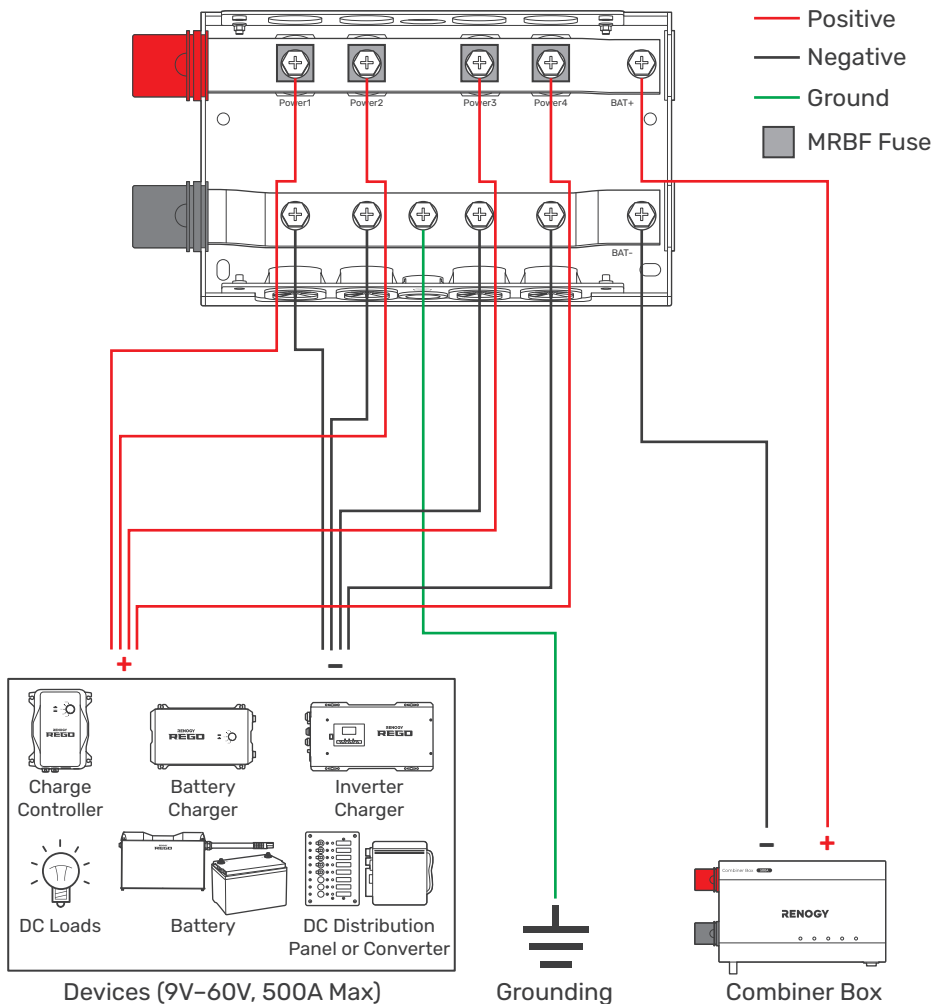

With ANL Fuses

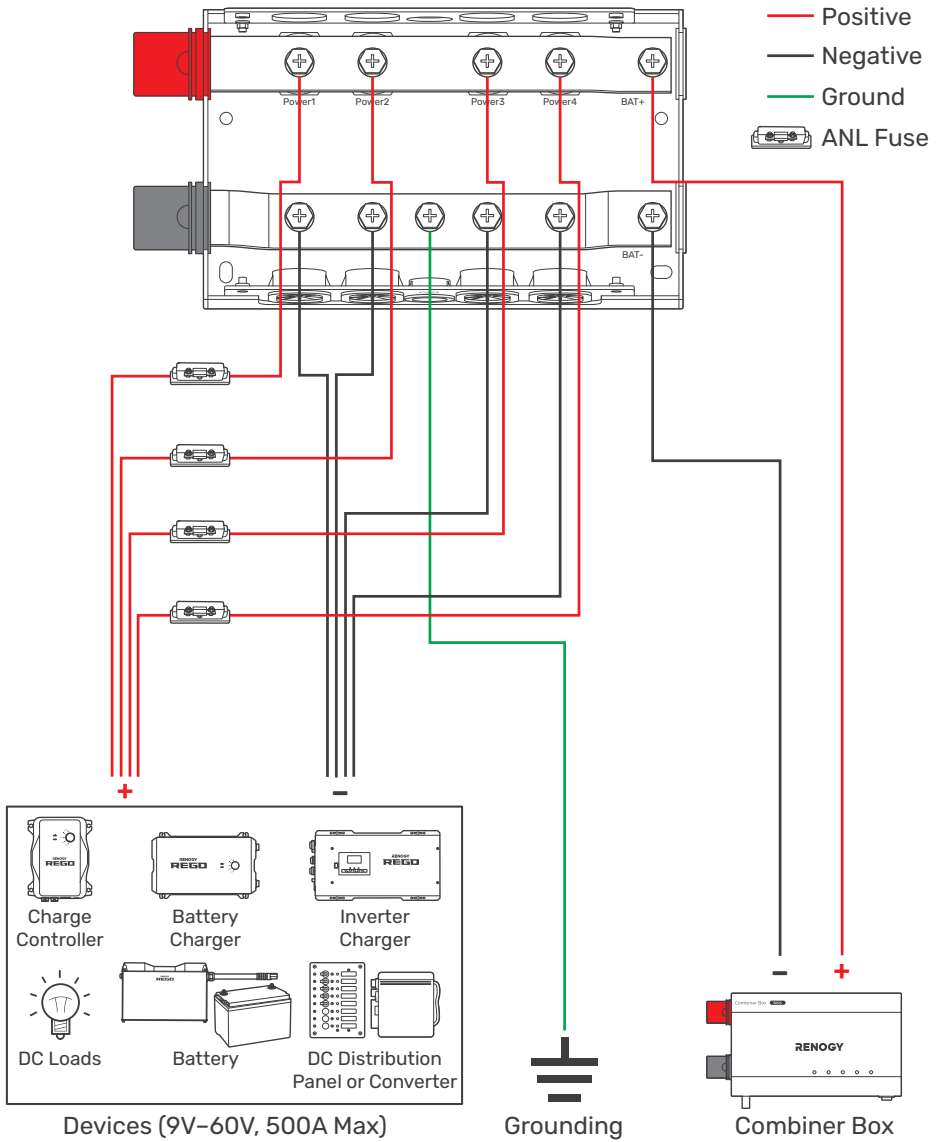

i The Voltage Sensor is not required in power systems involving ANL fuses. Accordingly, the LED indicators cannot work normally, and you cannot view device operational status in the DC Home app or Renogy ONE.

Dimensions

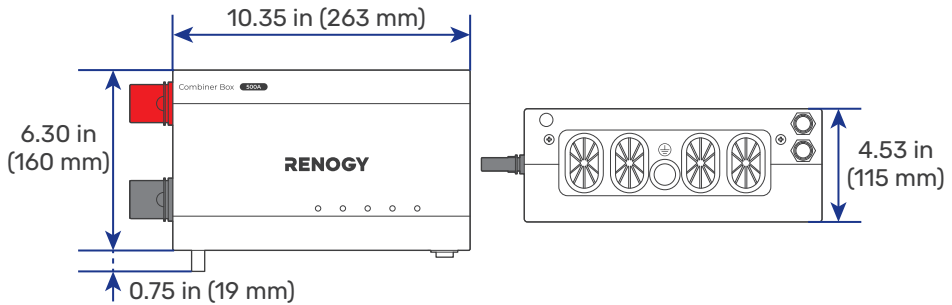

i Dimension tolerance: ± 0.2 in (0.5 mm)

How to Size Cables?

Size wires specific to the operating current of relevant devices. Refer to the table below for copper cable ampacities with different gauge sizes.

Cable Gauge Size	Ampacity	Cable Gauge Size	Ampacity
14 AWG (2.08 mm ²)	35A	2 AWG (33.6 mm ²)	190A
12 AWG (3.31 mm ²)	40A	1 AWG (42.4 mm ²)	220A
10 AWG (5.25 mm ²)	55A	1/0 AWG (53.5 mm ²)	260A
8 AWG (8.36 mm ²)	80A	2/0 AWG (67.4 mm ²)	300A
6 AWG (13.3 mm ²)	105A	4/0 AWG (107 mm ²)	405A
4 AWG (21.1 mm ²)	140A		

i The above values are from the NEC Table 310.15(B)16 for copper cables rated at 167°F (75°C), operating at an ambient temperature of no more than 86°F (30°C). Cables longer than 6 feet (1829 mm) may require thicker gauge wires to prevent excessive voltage drop in undersized wiring.

How to Install the 3/8 in Lugs (M10 Ring Terminals)?

The 3/8 in lugs are used to connect power supply devices such as batteries and charge controllers to the combiner box.

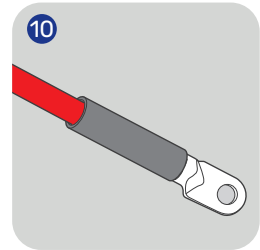
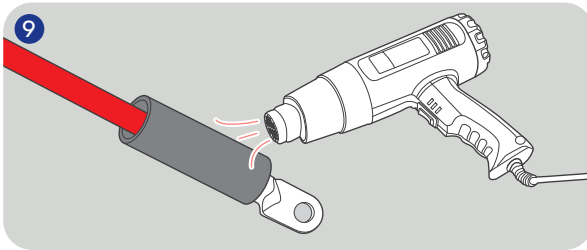
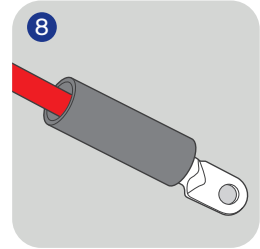
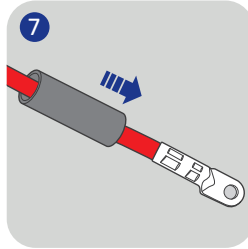
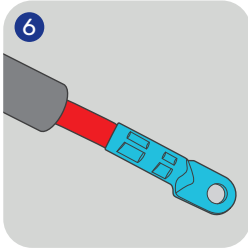
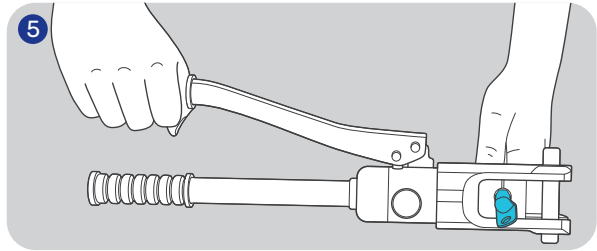
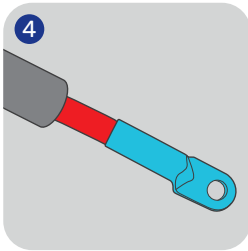
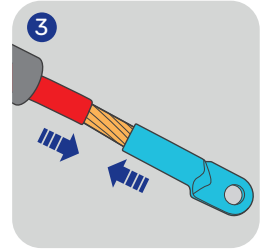
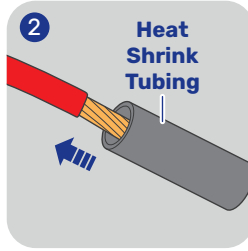
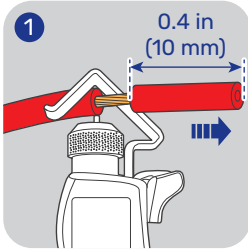

How to Connect Power Supply Devices to the Busbars Safely?

In wiring, prevent short circuits by consistently routing the positive cable ahead of the negative one through the cable grommet, adhering to the illustrated steps.

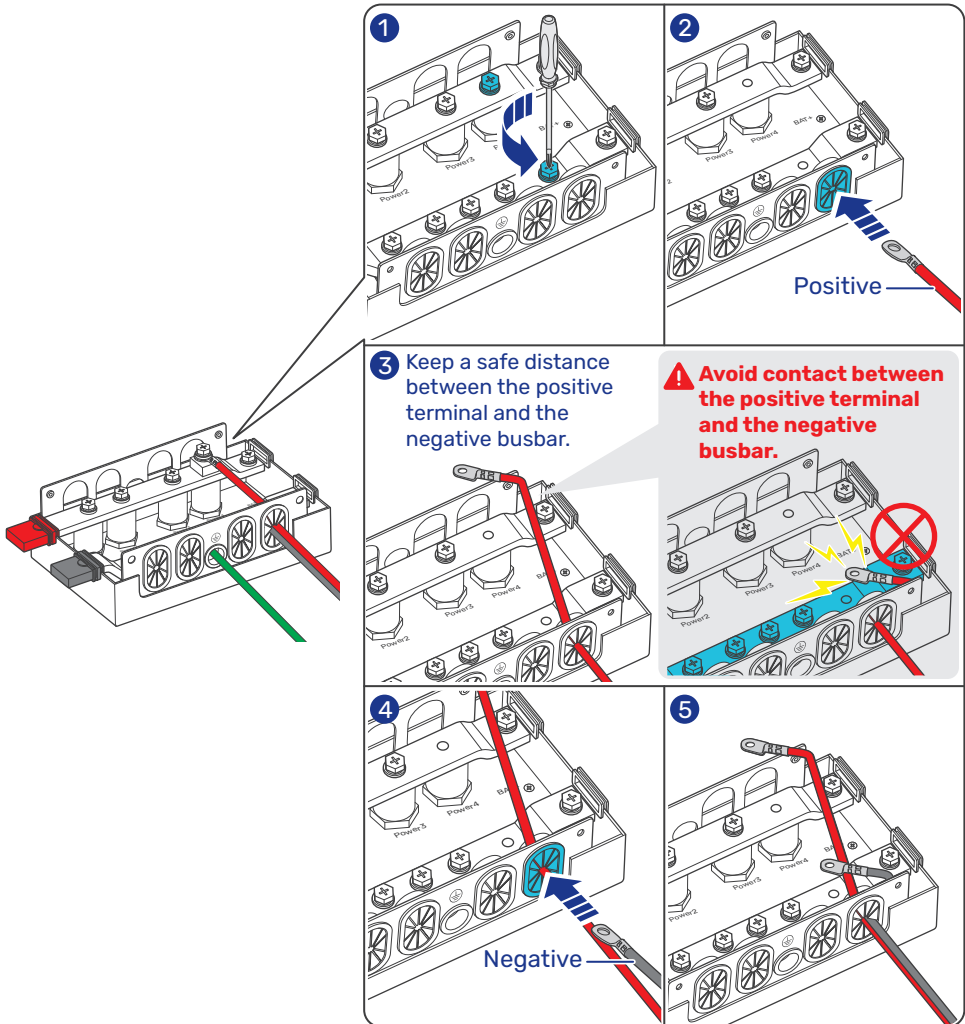



⚠ Ensure that the positive busbar terminal does not come into contact with the negative busbar terminal. Short circuits can damage connected batteries and devices.

Step 1. Plan a Mounting Site

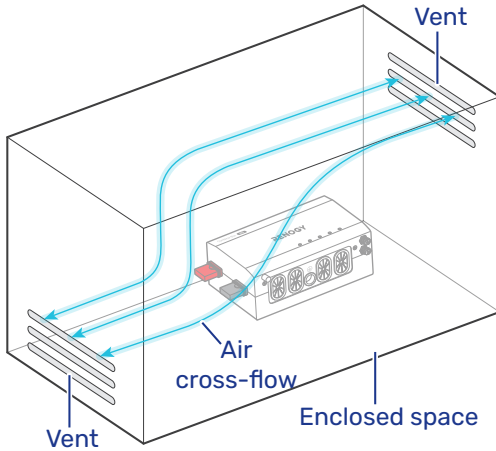
Install the combiner box in a clean, cool, and dry place. Keep water, oil, and dirt away from the combiner box, and protect it from direct sunlight.



 -4°F to 140°F
-20°C to 60°C

 0% to 99% RH,
non-condensing

i The combiner box can be mounted either on a floor or on a wall.

Step 2. Wear Insulating Gloves

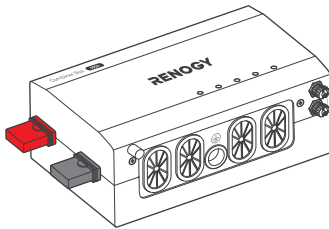

Insulating
Gloves

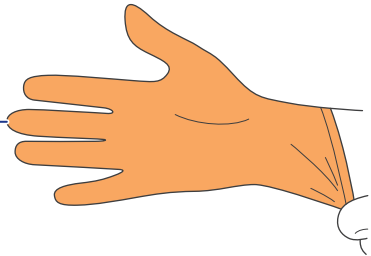

Step 3. Remove the Cover

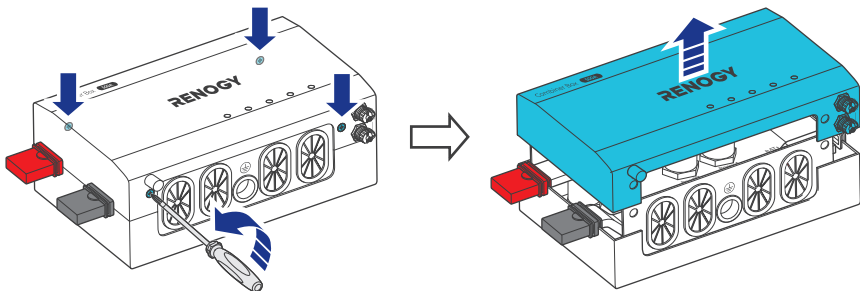

Step 4. Mount the Combiner Box

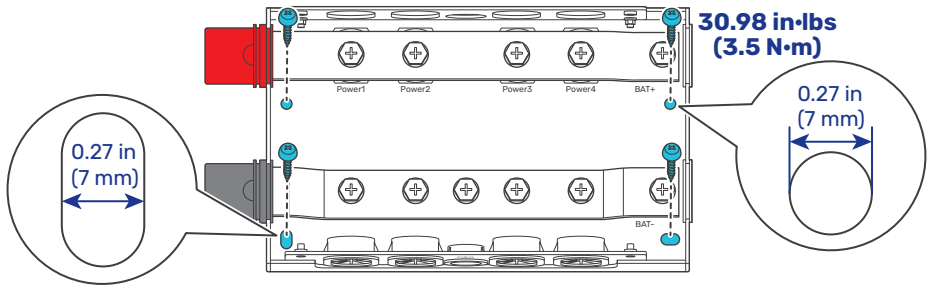

- i** Make sure that the combiner box is installed firmly to prevent it from falling off.
- i** Inspect the combiner box for any visible damage including cracks, dents, deformation, and other visible abnormalities. All terminal contacts shall be clean and dry, free of dirt and corrosion.

Step 5. Ground the Combiner Box

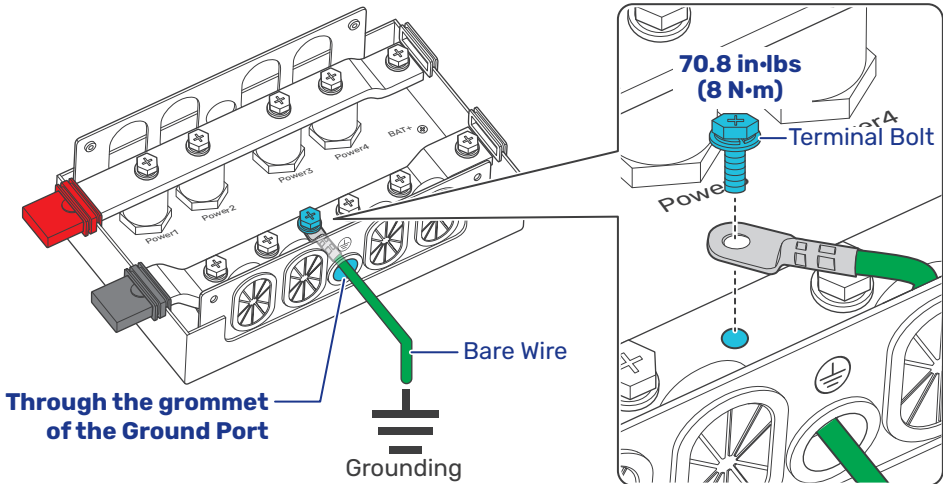





Step 6. Installing the Voltage Sensor (Optional)

The Voltage Sensor applies to power systems involving MRBF fuses. The Voltage Sensor monitors the fuse voltages at the combiner box terminals, allowing the combiner box to assess the normal operation (on or off) of the connected power supply device. You can check the device's operational status by the in-built LEDs or through the DC Home app or Renogy ONE Core. For LED indications, see "[LED Indicators & Troubleshooting](#)" in the manual.

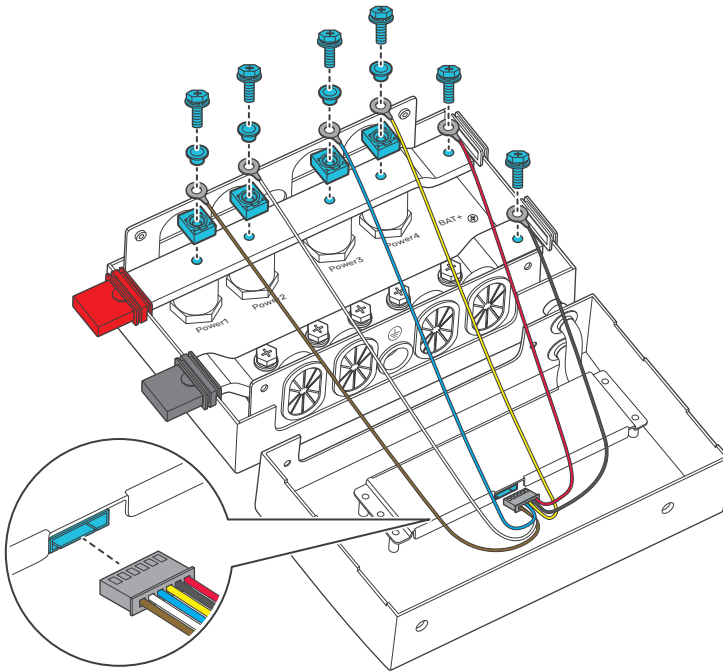
Connect the ring terminals of the voltage sensor to the positive terminals on the combiner box, and attach the other end (connector) to the signal port on the cover of the combiner box. Follow the cable sequencing and silkscreens outlined in the table below.

Voltage Sensor Color & Silk-screen	Combiner Box Terminal	Voltage Sensor Color & Silk-screen	Combiner Box Terminal
Red (BAT+)	BAT+	White (POWER2)	Power2
Black (BAT-)	BAT-	Blue (POWER3)	Power3
Brown (POWER1)	Power1	Yellow (POWER4)	Power4





-  Incorrect wiring between the combiner box and the voltage sensor leads to a failure in LED indications.
-  Install the MRBF fuses on the combiner box terminals followed by the voltage sensor.
-  To remove the voltage sensor, simply remove the connector from the combiner box.

Step 7. Connect Power Supply Devices to the Combiner Box

Install wires on power supply devices (charge controller, battery, inverter, and more) prior to connecting them to the combiner box. For details on how to install wires on the devices, see the user manual of the specific device.

Always install the negative terminals before positive ones. The following illustrations take connecting a REGO 12V 60A MPPT Solar Charge Controller to the combiner box as an example.

-  Ensure that the positive busbar terminal does not come into contact with the negative busbar terminal. Short circuits can damage connected batteries and devices. For detailed instructions, see "[How to Connect Power Supply Devices to the Busbars Safely?](#)" in the manual.
-  Check the polarity before connecting the cables. Reverse polarity can damage connected batteries and devices.
-  To ensure safe and reliable operation of the system, please follow the torque specifications of relevant devices recommended by the manufacturer securing cable connections. Over-tightening can cause terminal breakage, while loose connections can lead to terminal meltdown or fire hazards.

With MRBF Fuse

Recommended Components

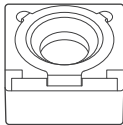

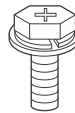

*MRBF Fuse

M8 x 30 mm



*Long Terminal Bolt
(with spring washer and flat washer)

-  Components marked with "*" are available on [renogy.com](https://www.renogy.com).
-  Choose proper MRBF fuses (not included) to meet specifications of the relevant devices. For details, see the user manuals of the relevant devices.

STEP-1 Install the negative

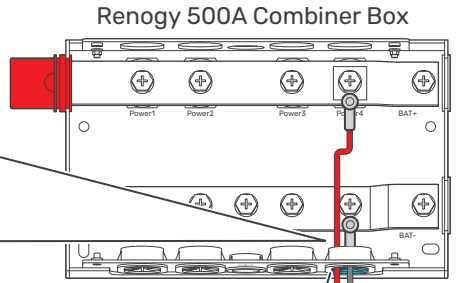
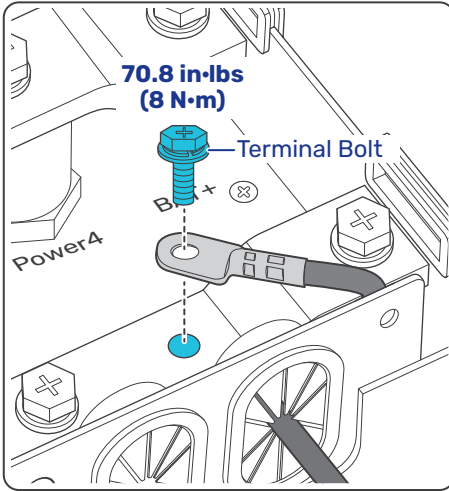

Through the grommet
of the Cable Grommet

Bare Wires

STEP-2 Install the MRBF fuse and positive

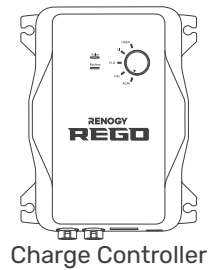
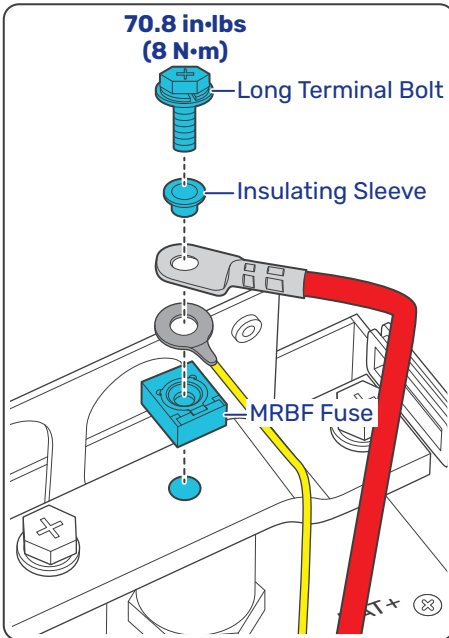

With ANL Fuse

Recommended Components

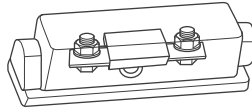

*ANL Fuse

- i** Choose proper ANL fuses (not included) to meet specifications of the relevant devices. For details, see the user manuals of the relevant devices.

STEP-1 Install the negative

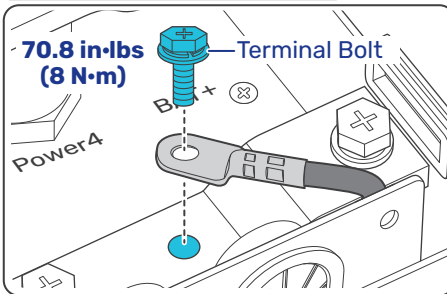

STEP-2 Install an ANL fuse

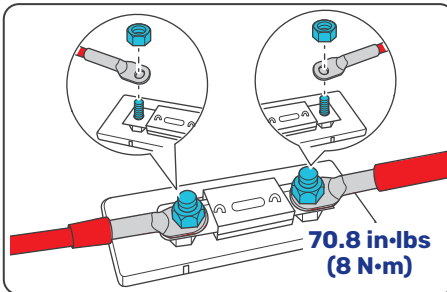

STEP-3 Install the positive

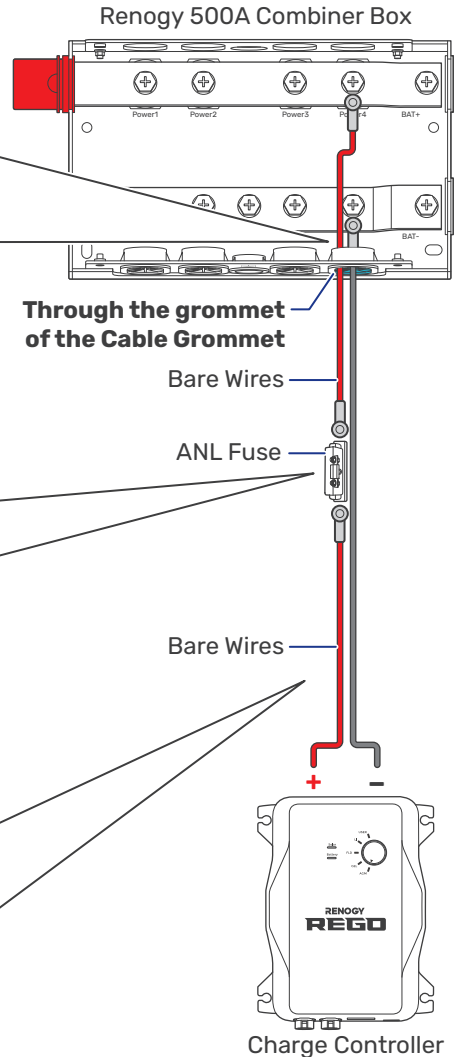
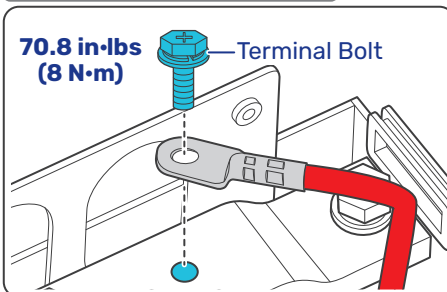

Step 8. Wire Inspection and Install the Cover

Verify that all cable connections are firmly and securely fastened. This step is essential to prevent any loose or unstable connections that could lead to operational issues or safety concerns.

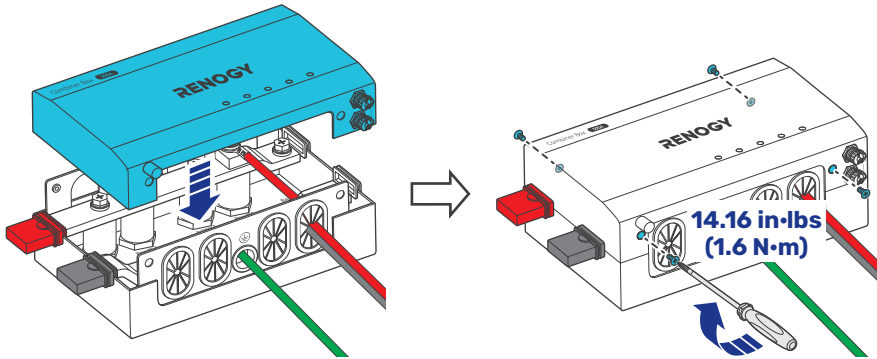

CAN Communication Wiring (Optional)

The Renogy 500A Combiner Box can communicate with other Renogy devices supporting CAN communication and monitoring devices through CAN (common area network) bus, also known as RV-C, enabling safe operation, smart control, remote monitoring, and programmable settings.

You can connect the combiner box to other Renogy devices supporting CAN communication for real-time inter-device data communication through either of the CAN Communication Ports. 7-Pin CAN Communication Terminal Plugs and 7-Pin CAN Communication Terminal Plug adapter cables are required for the wiring.

The wiring details vary depending on the wiring schemes. This user manual elaborates on inter-device wiring in two schemes: backbone and daisy chain networks.

i For technical support from Renogy, please contact us through [renogy.com/contact-us/](https://www.renogy.com/contact-us/).

To properly connect or disconnect the 7-Pin CAN Communication Terminal Plug to or from the combiner box, you should

1. Remove the dust cover from the CAN Communication Port on the combiner box.
2. Ensure that the plug is oriented vertically toward the CAN Communication Port.
3. Rotate the terminal fixing nut to loosen or secure the plug.

Shaking the terminal plug while plugging or unplugging it is not allowed.

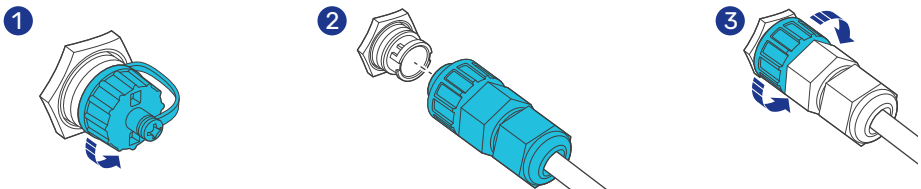

■ Backbone Network

Ensure 120Ω terminating resistors are installed at both ends of the RV-C bus for successful communication with Renogy devices supporting CAN communication. If the RV user manual does not determine if the RV-C bus has a built-in 120Ω termination resistor, call the RV manufacturer to confirm.

- i** If the RV-C bus does not have a built-in 120Ω termination resistor, the combiner box will not communicate properly with other Renogy devices supporting CAN communication. Please use the Daisy Chain Network for communication connections.

Connect devices to the combiner box according to the wiring diagram provided by the RV manufacturer. Choose proper communication cables according to your specific demands.

Recommended Tools & Accessories

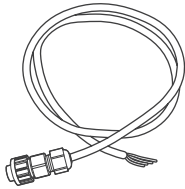

*7-Pin CAN Communication
Terminal Plug to Bare Drop Cable(s)

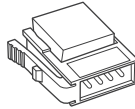

Drop Plugs

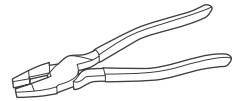

Split Joint Pliers

- i** Accessories marked with "*" are available on [renogy.com](https://www.renogy.com).
- i** The 7-Pin CAN Communication Terminal Plug to Bare Drop Cable is only for use with the combiner box. Please refer to the user manual of other devices for the communication cable types they require.
- i** The drop cable shall not exceed 19.6 feet (6 m), and the RV-C bus shall not exceed 98.4 feet (30 m).
- i** Choose the appropriate drop plugs that are compatible with the drop sockets used on the RV-C bus. Different RV manufacturers may use different types of drop sockets for inter-device communication connections. If you are unsure about the correct drop plug selection, consult with the RV manufacturer. In this manual, the Mini-Clamp II plug (4-pin) is used as an example.
- i** Different Drop Plugs follow different pinouts. Crimp the Drop Plugs on the Drop Cables following the correct pinout. If you are not sure about the Drop Plug pinout, check with the RV manufacturer.

Step 1: Install the Drop Plugs on the bare end of the 7-Pin CAN Communication Terminal Plug to Bare Drop Cable. The yellow CAN_H wire goes to pin 2, the green CAN_L wire goes to pin 3. Leave pin 1 and pin 4 empty.

Step 2: Squeeze the crimp areas of the Drop Plugs with the Split Joint Pliers.

Step 3: Locate the drop tap (not included) on the RV-C bus that is the closest to the installation site of the combiner box. The drop taps are usually located above the entry door, in the bathroom, or under the bed in the RV.

Step 4: Connect the Drop Plugs on the drop cables and other Renogy devices supporting CAN communication to the drop sockets on the drop tap.

Step 5: Insert the 7-Pin CAN Communication Terminal Plug into any of the CAN Communication Ports of the combiner box.

- i** If you fail to locate the drop taps, please contact the RV manufacturer for help.
- i** Different drop taps are used on the RV-C bus by different RV manufacturers. This user manual takes the 4-socket drop tap as an example.

STEP-1 Install Cables on the RV-C bus

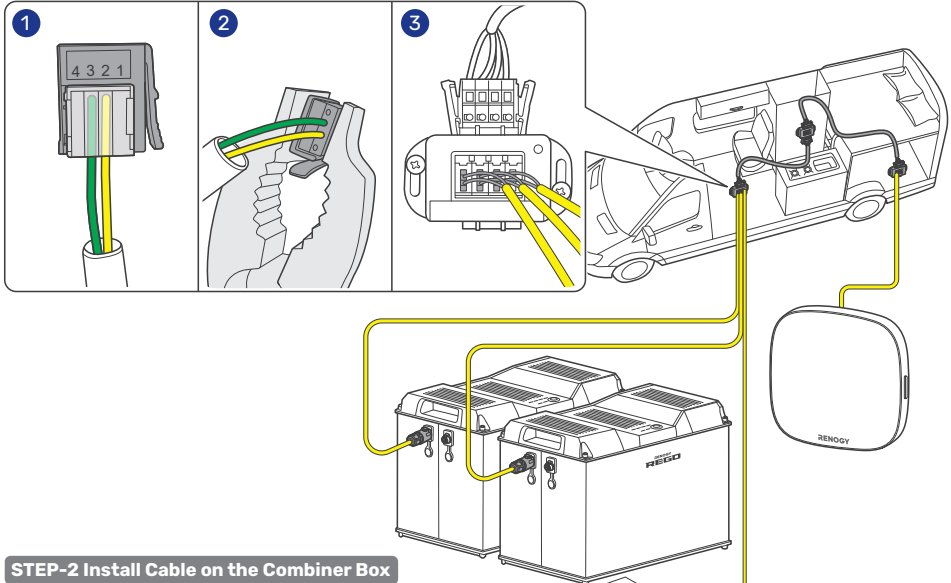

STEP-2 Install Cable on the Combiner Box

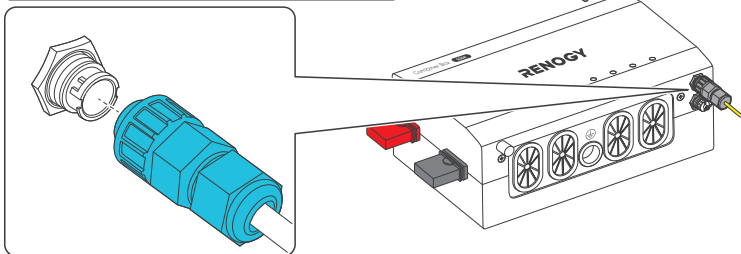

Daisy Chain Network

The daisy chain network applies to RVs that are not integrated with RV-C buses.

Please select the appropriate adapter cable based on the type of the CAN Communication Port specific to the device. For example:

- Combiner Box to RENOGY ONE: 7-Pin CAN Communication Terminal Plug to RJ45 Communication Adapter Cable
- Combiner Box to REGO devices: 7-Pin CAN Communication Terminal Plug to LP16 Plug (7-Pin) Communication Adapter Cable
- Combiner Box to Renogy 12V/24V 50A IP67 Dual Input DC-DC On-Board with MPPT Battery Charger: 7-Pin CAN Communication Cable(s)

- i** This section is based on an 7-Pin CAN Communication Terminal Plug to LP16 Plug (7-Pin) Communication Adapter Cable.
- i** Different drop taps are used on the RV-C bus by different RV manufacturers. This user manual takes the 4-socket drop tap as an example.

Recommended Accessories

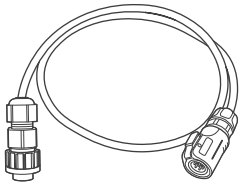

*7-Pin CAN Communication Terminal Plug to LP16 Plug (7-Pin) Communication Adapter Cable(s)

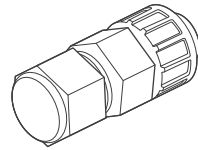

*7-Pin CAN Communication Terminal Plug

- i** Accessories marked with "*" are available on [renogy.com](https://www.renogy.com).
- i** The communication cable should be less than 19.6 feet (6 m).
- i** Choose proper terminal plugs based on the specific CAN ports.

The quantity of adapter cables and plugs varies based on the position of the combiner box in the daisy chain network. When the combiner box is positioned at either the first or the last device in the daisy chain network, one 7-Pin CAN Communication Terminal Plug and one adapter cable are required. In scenarios where the combiner box is located in the middle of the daisy chain network, two adapter cables are needed.

Step 1: Connect devices in series with the combiner box through either of the CAN Communication Ports with the Communication Cable(s) (sold separately).

Step 2: Plug the Terminator Plugs (sold separately) into the vacant CAN Communication Ports on the first and last devices.

Combiner Box is Positioned at the First or Last in the Daisy Chain Network

STEP-1 Install Cables on devices

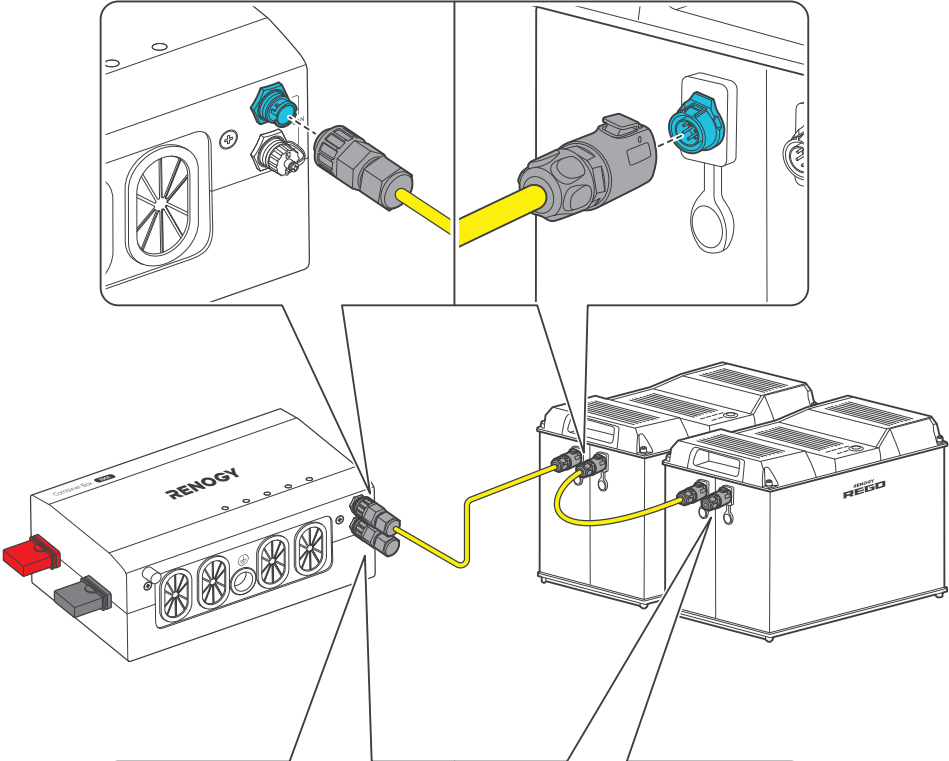

STEP-2 Install Plugs on devices

Combiner Box is in the Middle of the Daisy Chain Network

STEP-1 Install Cables on devices

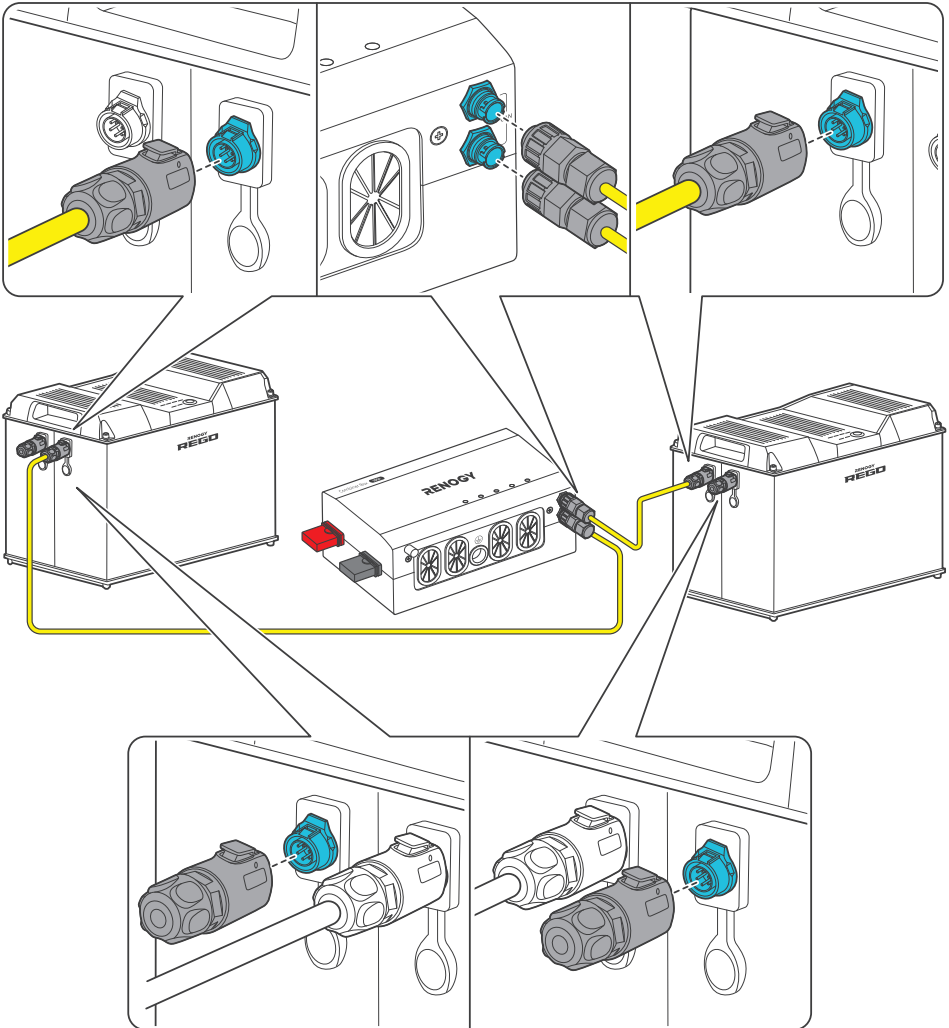

STEP-2 Install Plugs on devices

Interconnecting Combiner Boxes

This chapter discusses how to connect several combiner boxes to each other for system expansion. You can interconnect up to six combiner boxes in your system.

Step 1: Remove the dust covers and extended positive/negative terminals from the first combiner box. Similarly, remove the dust covers from the positive and negative busbars from the second combiner box.

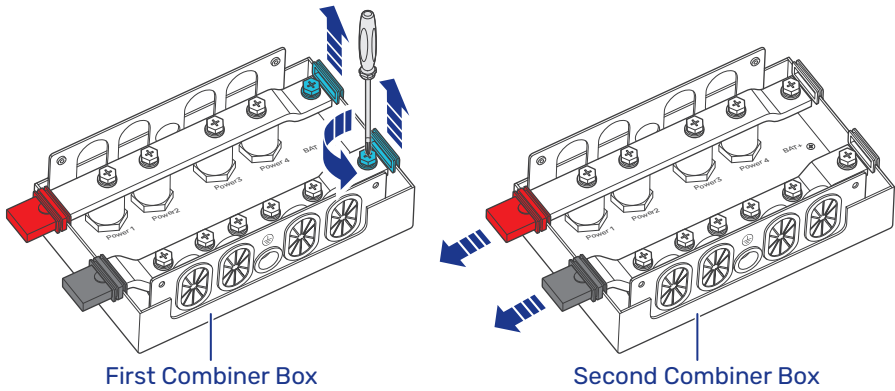

Step 2: Align the busbar ports.

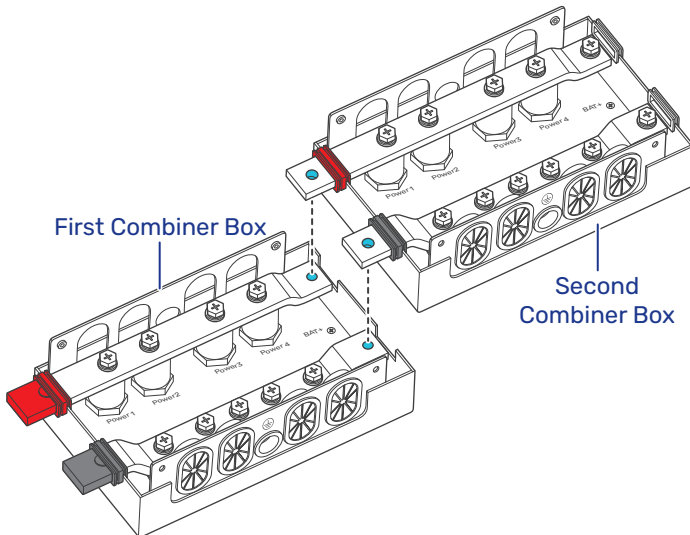

Step 3: Install the terminal bolts, spring washers, and flat washers on the busbar ports.

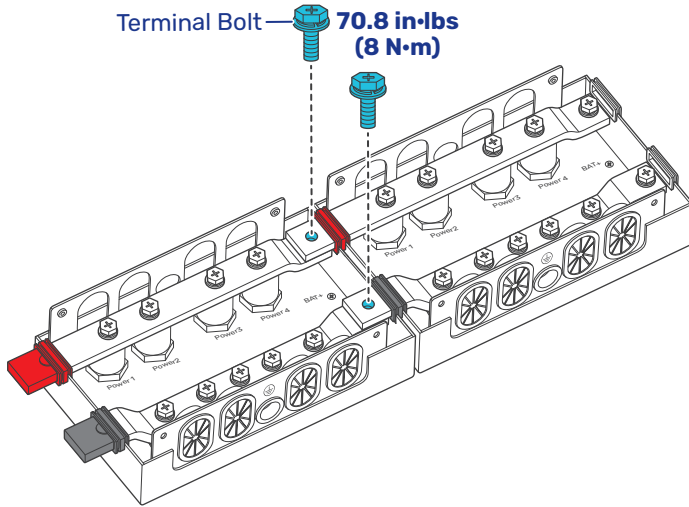

LED Indicators & Troubleshooting

The combiner box automatically activates upon powering on, and the LED indicators operate in accordance with the corresponding operating status of the connected device.

The LEDs serve to indicate the circuit status connected to the terminals on the combiner box. Power1, Power2, Power3, and Power4 are linked to power supply devices, while BAT+ LED specifically represents the interconnection status of the combiner box.

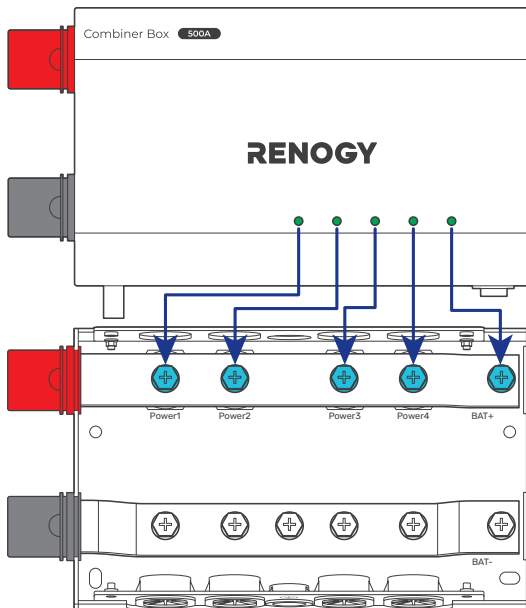

LED Status	Device Circuit
Solid green	No Fault
Solid red	Fault
Off	Unconnected device

i When interconnecting combiner boxes, a green BAT indicator light indicates a successful expansion, while the light being turned off indicates an unsuccessful expansion.

If the LED indicator light turns red or fails to light up, please follow the detailed troubleshooting steps below:

1. Check if the fuse has blown. Replace the blown fuse with a new one.
2. Ensure that the ring terminals are securely installed and there are no loose connections.
3. Verify that all cables are undamaged and the circuits are clear.
4. Ensure that the voltage sensor is installed correctly.

i For technical support, contact our technical service through renogy.com/contact-us.

Monitoring

Depending on the specific application, the combiner box can establish either short-range or long-range communication connections with monitoring devices. These monitoring devices facilitate real-time monitoring, programming, and complete system management, offering comprehensive control and enhanced flexibility.

- i** Make sure the Bluetooth of your phone is turned on.
- i** The version of the DC Home app might have been updated. Illustrations in the user manual are for reference only. Follow the instructions based on the current app version.
- i** Make sure that the combiner box is properly installed and powered on before it is paired with the DC Home app.
- i** To ensure optimal system performance, keep the phone within 10 feet (3 m) of the combiner box.

To ensure optimal connection performance, download the latest DC Home app. Login to the app with your account.

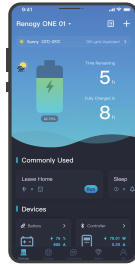

Short-Range Monitoring

If only short-range monitoring is required, connect the combiner box to the DC Home app directly through the Bluetooth of your phone.

Step 1: Open the DC Home app. Tap + to search for new devices.

Step 2: Tap **Confirm** to add the newly found device to the device list.

Step 3: Tap the combiner box icon to enter the device information interface.

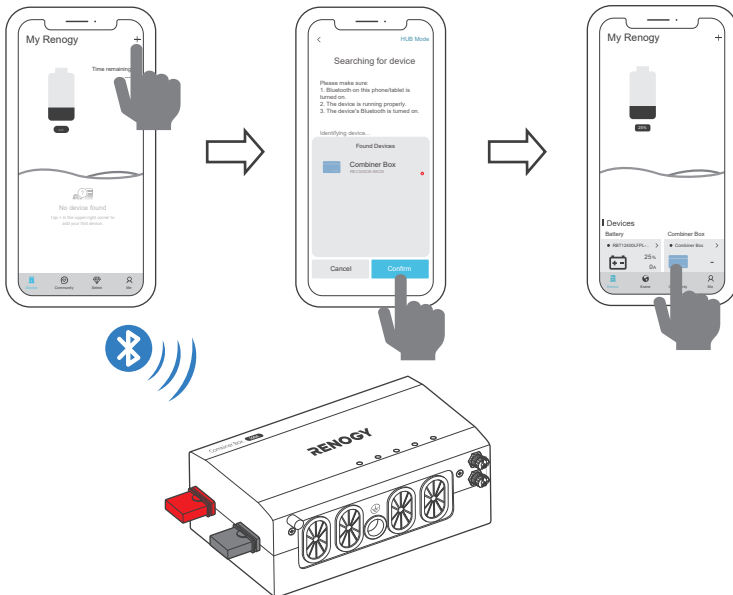



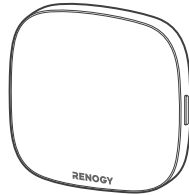

Wireless Long-Range Monitoring

If long-range communication and programming are required, connect the combiner box to Renogy ONE (sold separately) through Bluetooth, and then pair Renogy ONE with the DC Home app with the DC Home app.

Recommended Components



*RENOGY ONE Core

-  Components marked with "*" are available on [renogy.com](https://www.renogy.com).
-  Make sure that the Renogy ONE is powered on before the connection.
-  For instructions on Renogy ONE, see [Renogy ONE Core User Manual](#).
-  Make sure the combiner box does not communicate with any other device.

Step 1: Connect the combiner box to Renogy ONE through the Bluetooth of your phone.

Step 2: Pair the Renogy ONE with the DC Home app through Wi-Fi or by scanning the QR code in the Renogy ONE. On Renogy ONE, go to "**System > Settings > Pair with App**" to get the QR code.

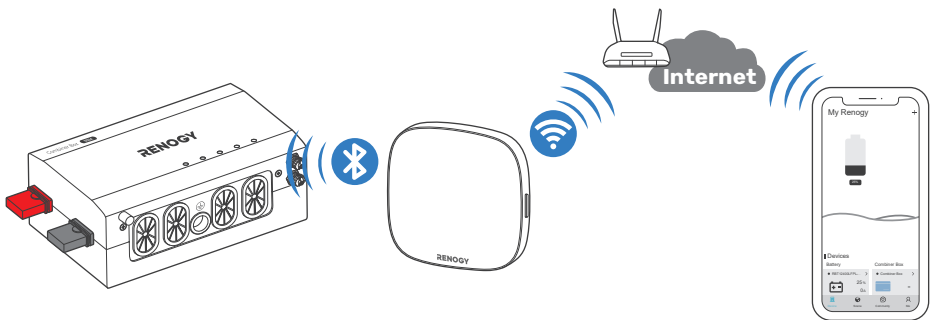

Wired Long-Range Monitoring (Backbone Network)

If long-range communication and programming are required, connect the combiner box to Renogy ONE through a RJ45 Plug to Bare Drop cable, and then pair Renogy ONE with the DC Home app.

Recommended Components & Accessories



*RENOGY ONE Core

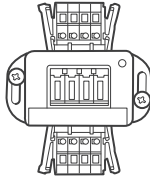

Common Drop Tap



RJ45 Plug to Bare Drop Cable

- i** Components marked with "*" are available on [renogy.com](https://www.renogy.com).
- i** Make sure that the Renogy ONE is powered on before the connection.
- i** For instructions on Renogy ONE, see [Renogy ONE Core User Manual](#).
- i** Make sure the combiner box does not communicate with any other device.
- i** Select the appropriate communication cable (sold separately) according to the distance between devices. The communication cable should be less than 19.6 feet (6 m).
- i** Different terminal block plugs are used on different Common Drop Taps and follow different pinouts. If you are unsure about the pinout of the terminal block plug, contact the RV manufacturer.

Step 1: Replace the terminated drop tap at either end of the RV-C bus with the Common Drop Tap (not included). Secure the bare wires of the Drop Cable (not included) onto the terminal block plug of the Common Drop Tap following the terminal block plug pinout. Plug the Drop Cable to the RJ45 port of Renogy ONE.

Step 2: Monitor and program the complete system on Renogy ONE or the DC Home app.

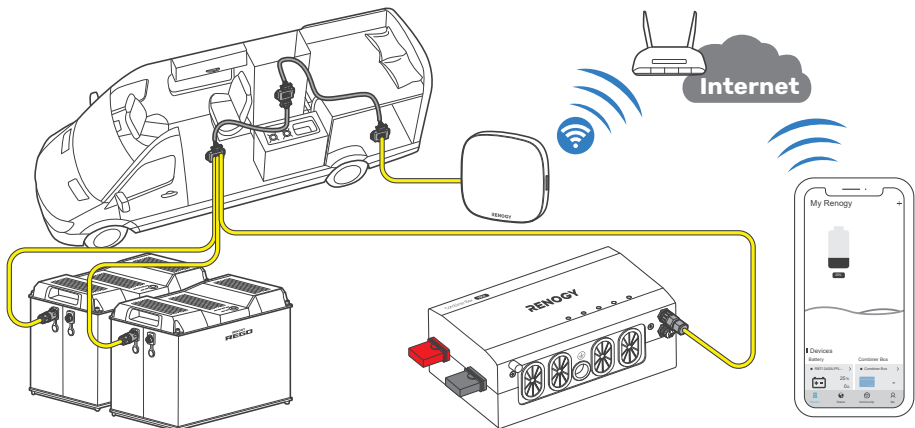

Wired Long-Range Monitoring (Daisy Chain Network)

If long-range communication and programming are required, connect the combiner box to Renogy ONE through wires, and then pair Renogy ONE with the DC Home app.

Recommended Components & Accessories



*RENOGY ONE Core

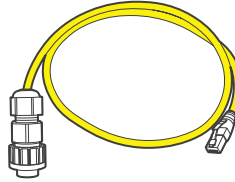

*7-Pin CAN Communication Terminal Plug to RJ45 Communication Adapter Cable

- i** Components marked with "*" are available on [renogy.com](https://www.renogy.com).
- i** The 7-Pin CAN Communication Terminal Plug to RJ45 Communication Adapter Cable is exclusively designed for scenarios where the Combiner Box is positioned at the first or last in the daisy chain network. If the Combiner Box is in the middle of the daisy chain network, please select the appropriate adapter cable based on the CAN communication port type of the first or last device.
- i** Make sure that the Renogy ONE is powered on before the connection.
- i** For instructions on Renogy ONE, see [Renogy ONE Core User Manual](#).
- i** Make sure the combiner box does not communicate with any other device.
- i** Select the appropriate communication cable (sold separately) according to the distance between devices. The communication cable should be less than 19.6 feet (6 m).

Step 1: Remove the Terminator Plug from the Renogy devices supporting CAN communication at either end of the daisy chain.

Step 2: Connect the Renogy ONE to the free CAN Communication Port on the Renogy devices supporting CAN communication with the Communication Adapter Cable (sold separately).

Step 3: Pair Renogy ONE with the DC Home app. Monitor and program the complete system on the Renogy ONE or the DC Home app.

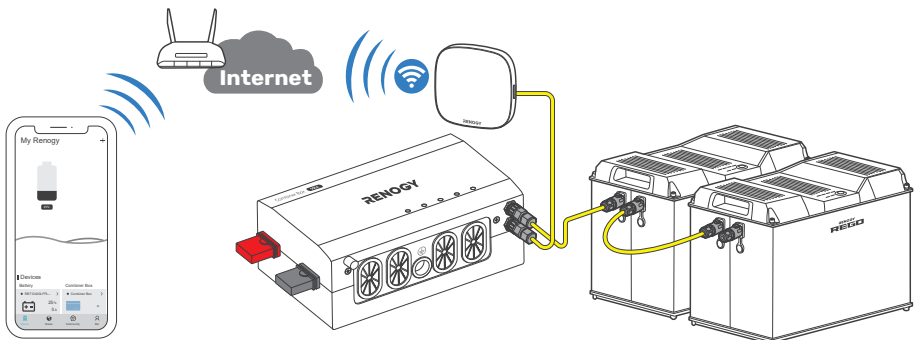

Specifications

Voltage Range	9V to 60V DC
Rated Current	500A
Connector	M8 Busbar
Enclosure Material	Sheet Metal
Dimensions	10.35 x 6.30 x 4.53 in 263 x 160 x 115 mm
Weight	4.85 lbs / 2.2 kg
Busbar Material	Tinned Copper
Busbar Dimensions	0.16 x 1.18 in 4 x 30 mm
Recommended Terminal Torque	70.8 in•lbs / 8 N•m
Operating Temperature Range	-4°F to 140°F / -20°C to 60°C
Storage Temperature Range	-40°F to 176°F / -40°C to 80°C
Humidity	0-99% RH (non-condensing)
Protection Class	IP22
Communication	CANBus and ModBus (Bluetooth)

Maintenance

Inspection

Please perform regular inspections following the steps below:

- Examine the external appearance of the combiner box. The casing and terminals of the combiner box shall be clean, dry, and free of corrosion.
- Check the continuity of the fuses. Replace any blown fuses.
- Check the cables and connections. Replace any damaged cables and tighten any loose connections.

i In certain application scenarios, corrosion may occur around the terminals. Corrosion can cause increased resistance and poor contact. It is recommended to regularly apply insulation grease to each terminal. Insulation grease can form a moisture-resistant seal and protect the terminals from corrosion.

Cleaning

Please clean the combiner box at regular intervals following the steps below.

- Disconnect the devices and batteries or battery combiner box from the combiner box.

- Clean the casing and terminals. The household cleaner can be used if the combiner box is extremely dirty.
- Use a clean cloth to dry the combiner box. Ensure that the area surrounding the combiner box remains clean and dry.
- Reconnect the necessary devices to the combiner box.

Important Safety Instructions

General

- Wear proper protective equipment and use insulated tools during installation and operation. Do not wear jewelry or other metal objects when working on or around the combiner box.
- Keep the combiner box out of the reach of children.
- Do not dispose of the combiner box as household waste. Comply with local, state, and federal laws and regulations and use recycling channels as required.
- In case of fire, put out the fire with a FM-200 or CO₂ fire extinguisher.
- Do not expose the combiner box to flammable or harsh chemicals or vapors.
- Clean the combiner box regularly.
- It is recommended that all cables should not exceed 32.8 ft (10 m) because excessively long cables result in a voltage drop.
- The cable specifications listed in the user manual account for critical, less than 3% voltage drop and may not account for all configurations.
- Do not expose the combiner box to strong electrostatic fields, strong magnetic fields, or radiation.

Combiner Box Safety

- Please keep the combiner box away from water, heat sources, sparks, and hazardous chemicals.
- Do not puncture, drop, crush, burn, penetrate, shake, strike, or step on the combiner box.
- Do not repair, tamper with, or modify the combiner box.
- Do not touch any terminals.
- Please make sure all devices have been disconnected before working on the combiner box.
- Do not place tools on top of the combiner box.
- Do not insert foreign objects into the positive and negative terminals of the combiner box.
- Ensure the connected devices are off before connecting them to the combiner box.

Renogy Support

To discuss inaccuracies or omissions in this quick guide or user manual, visit or contact us at:

[G | renogy.com/support/downloads](https://renogy.com/support/downloads)

 contentservice@renogy.com

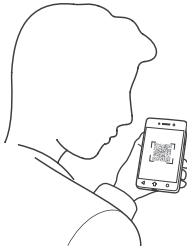

Questionnaire Investigation



To explore more possibilities of solar systems, visit Renogy Learning Center at:

[G | renogy.com/learning-center](https://renogy.com/learning-center)

For technical questions about your product in the U.S., contact the Renogy technical support team through:

[G | renogy.com/contact-us](https://renogy.com/contact-us)

 1(909)2877111

For technical support outside the U.S., visit the local website below:

Canada |  | ca.renogy.com

China |  | www.renogy.cn

Australia |  | au.renogy.com

Japan |  | jp.renogy.com

South Korea |  | kr.renogy.com

Germany |  | de.renogy.com

United Kingdom |  | uk.renogy.com

Other Europe |  | eu.renogy.com



Renogy Empowered

Renogy aims to empower people around the world through education and distribution of DIY-friendly renewable energy solutions.

We intend to be a driving force for sustainable living and energy independence.

In support of this effort, our range of solar products makes it possible for you to minimize your carbon footprint by reducing the need for grid power.



Live Sustainably with Renogy

Did you know? In a given month, a 1 kW solar energy system will...



Save 170 pounds of coal from being burned



Save 300 pounds of CO₂ from being released into the atmosphere



Save 105 gallons of water from being consumed



Renogy Power PLUS

Renogy Power Plus allows you to stay in the loop with upcoming solar energy innovations, share your experiences with your solar energy journey, and connect with like-minded people who are changing the world in the Renogy Power Plus community.



@Renogy Solar



@renogyofficial



@Renogy

Renogy reserves the right to change the contents of this manual without notice.

